

2-1" DIA. HOLES FOR 3/4" BOLT, WASHER & NUT, (SEE NOTE 3)

**SECTION C-C**

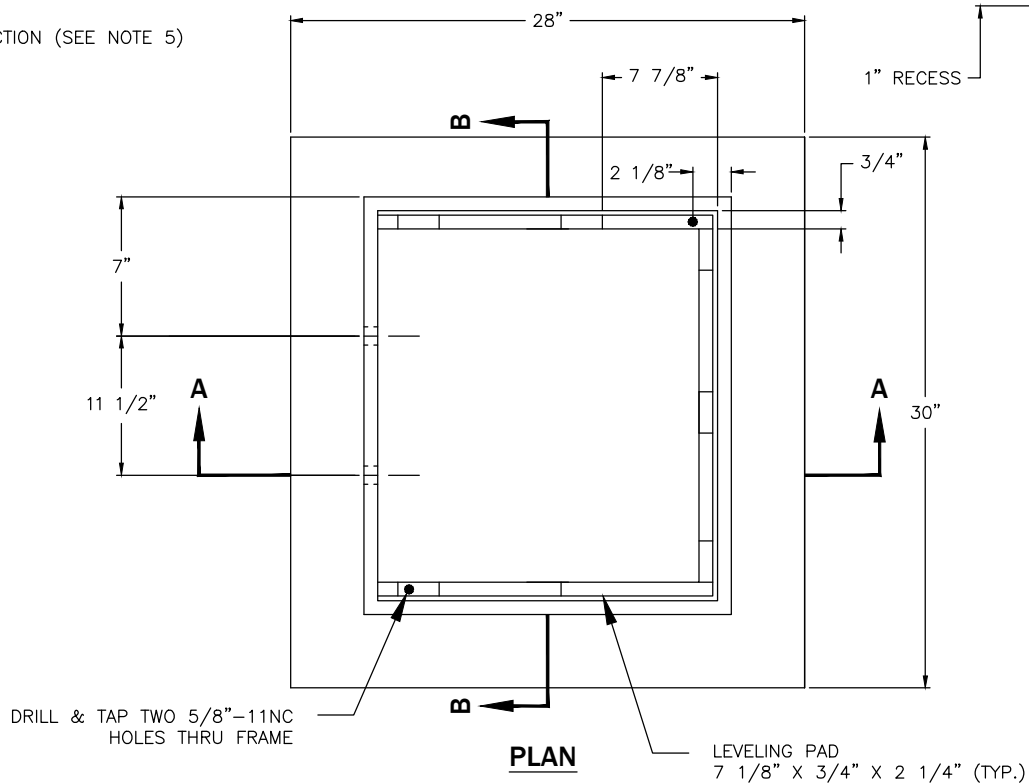

**PLAN**

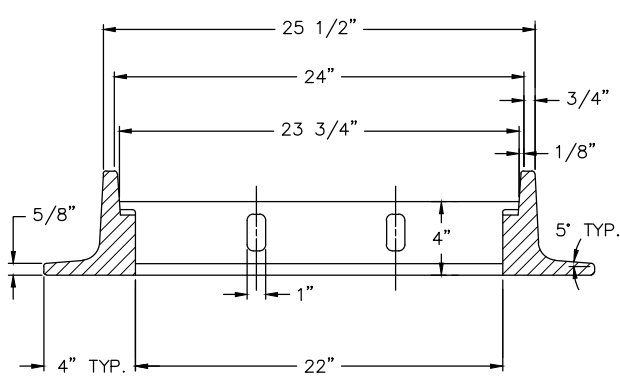
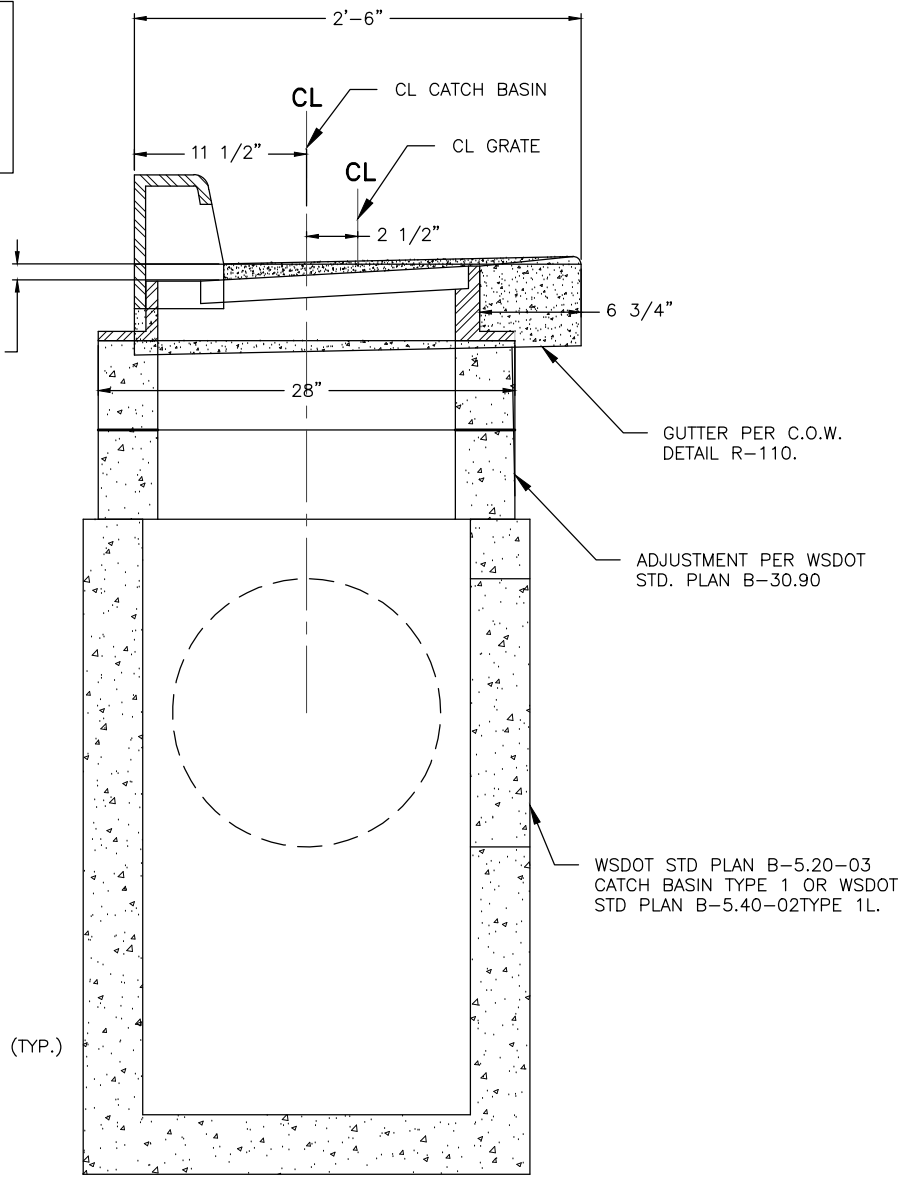

**SECTION B-B**

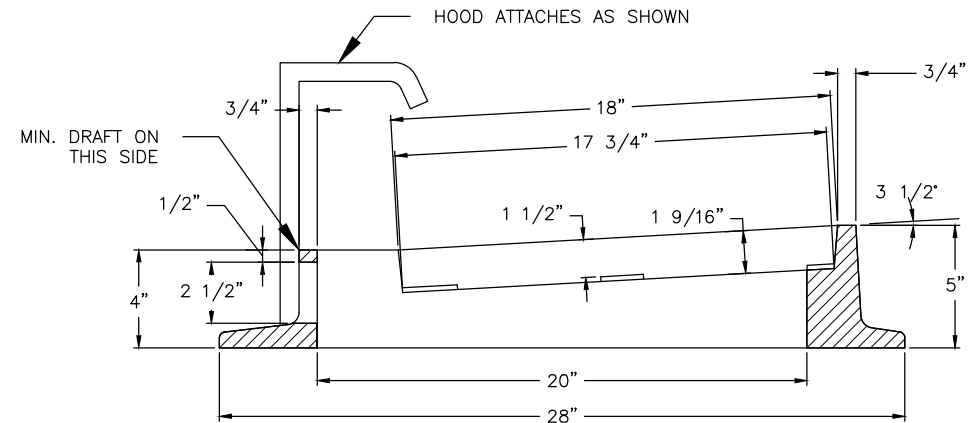

**SECTION A-A**

**THROUGH CURB INLET NOTES:**

1. MATERIAL IS CAST IRON ASTM A48 CLASS 30.
2. PATTERN ON TOP SURFACE OF HOOD SHALL BE  $\frac{3}{16}$ -INCH NON-SKID DIAMOND.
3. BOLT, WASHER, AND NUT SHALL BE GALV. OR CORROSION RESISTANT.
4. THROUGH CURB INLET EQUAL TO OLYMPIC SM52(05).
5. GUTTER SHALL BE CONSTRUCTED PER CITY OF WENATCHEE DETAIL R-100.

**NOTES:**

1. THIS INLET REQUIRES THE PRECAST CATCH BASIN UNIT TO BE ROTATED 90 DEGREES SO THAT THE NARROW SIDE IS PARALLEL TO THE CURB LINE. WHEN CALCULATING OFFSETS FROM CURB TO CL OF THE PRECAST CATCH BASIN, PLEASE NOTE THAT THE CL OF THE GRATE IS NOT THE CL OF THE PRECAST CATCH BASIN. SEE SECTION A
2. THE DIMENSIONS OF THE FRAME AND HOOD MAY VARY SLIGHTLY AMONG DIFFERENT MANUFACTURERS. THE FRAME MAY HAVE CAST FEATURES INTENDED TO SUPPORT A DEBRIS GUARD. HOOD UNITS MAY BE MOUNTED INSIDE OR OUTSIDE OF THE FRAME. THE HOOD MAY INCLUDE CASTING LUGS. THE TOP OF THE HOOD MAY BE CAST WITH A PATTERN.
3. ATTACH THE HOOD TO THE FRAME WITH TWO 3/4-INCH x 2-INCH HEX HEAD BOLTS, NUTS, AND OVERSIZE WASHERS. THE WASHERS SHALL HAVE DIAMETERS ADEQUATE TO ENSURE FULL BEARING ACROSS THE SLOTS.
4. ONLY DUCTILE IRON VANED GRATES SHALL BE USED. SEE WSDOT STANDARD PLANS RECTANGULAR GRATE B-30.30 AND BI-DIRECTIONAL GRATE B-30.40 FOR GRATE DETAILS.
5. THIS PLAN IS INTENDED TO SHOW THE INSTALLATION DETAILS OF A MANUFACTURED PRODUCT. THIS PLAN IS NOT INTENDED TO SHOW THE SPECIFIC DETAILS NECESSARY TO FABRICATE THE CASTINGS DEPICTED IN THIS DRAWING.

**STANDARD DETAIL  
THROUGH CURB INLET**



SCALE: AS SHOWN	DATE DRAWN	REVISIONS									
		DATE	INITIAL	DATE	INITIAL	DATE	INITIAL				
DESIGNED SK	2/21/2006	4/9/2015	RDH	4/13/2015	RDH	7/25/2016	DMN	03/31/2023	JTB	03/31/2023	JTB
DRAWN RLK	CHECKED DMN										
APPROVED BY	DATE APPROVED										

DETAIL NO.  
**D-300**

PAGE  
**1 OF 1**

STANDARD SPECIFICATIONS  
7-05  
9-05.15(2)